



**Gas cylinder cabinet G-ULTIMATE-90**  
**Model G90.205.120, laboratory white (sim. RAL 9016)**

**Safe and approved storage of flammable or toxic gases in working areas – for up to 4 x 50-litre gas cylinders**

**Function / construction:**

- **No unauthorised use:** doors lockable with profile cylinder (integration in an existing locking system possible)
- **Easy alignment:** adjusting aids to compensate for uneven floor
- **Easy mounting of connecting pipes and gas fittings:** large interior height (1890 mm), many lead-through possibilities on the top of the cabinet
- **Ventilation:** integrated air ducts ready for connection (DN 75) to a technical exhaust, even ventilation inside the cabinet
- **Tested and certified:** according to the stricter GS principles

**Available equipment:**

- Cylinder retainer – variable installation in the cabinet, flexibly adjustable in depth, across the entire width of the cabinet
- Comfort interior equipment – complete with mounting rails, rolling ramp (L = 350 mm) with pneumatic damper, cylinder retainer and matching tension belts
- Standard interior equipment – complete with mounting rails, rolling ramp and cylinder retainer
- Lateral cylinder retainer – for two 10-litre cylinders, alternatively in height adjustable version (no tools required)

**Dimensions**

<b>Width (external)</b>	1198.00 mm
<b>Depth (external)</b>	615.00 mm
<b>Height (external)</b>	2050.00 mm
<b>Width (internal)</b>	1045.00 mm
<b>Depth (internal)</b>	400.00 mm
<b>Height (internal)</b>	1858.00 mm

The available internal dimensions can vary depending on the interior equipment package.

**Weight / Load**

<b>Weight without interior equipment</b>	610 kg
<b>Distributed load</b>	625.00 kg/m <sup>2</sup>
<b>Maximum load</b>	600 kg

**Ventilation**

<b>Extraction air</b>	75 DN
<b>Minimum exhaust air quantity 10 times</b>	8 m <sup>3</sup> /h
<b>Minimum exhaust air quantity 120 times</b>	93 m <sup>3</sup> /h

For further details of the lead-through possibilities and exhaust air please have a closer look to EN 14470-2.

**Colouring / Surface finish**

<b>Body colour code</b>	
<b>Body colour</b>	Laboratory white (sim. RAL 9016)
<b>Body surface finish</b>	plain
<b>Door / Drawer colour code</b>	
<b>Door / Drawer colour</b>	Laboratory white (sim. RAL 9016)
<b>Door / Drawer surface finish</b>	plain

**General Information**

<b>Number of doors</b>	2
<b>Door opening angle</b>	180.00°
<b>Depth with open doors</b>	1238 mm
<b>x 50-litre gas cylinders</b>	4 piece
<b>Customs tariff number</b>	94032080

Front view

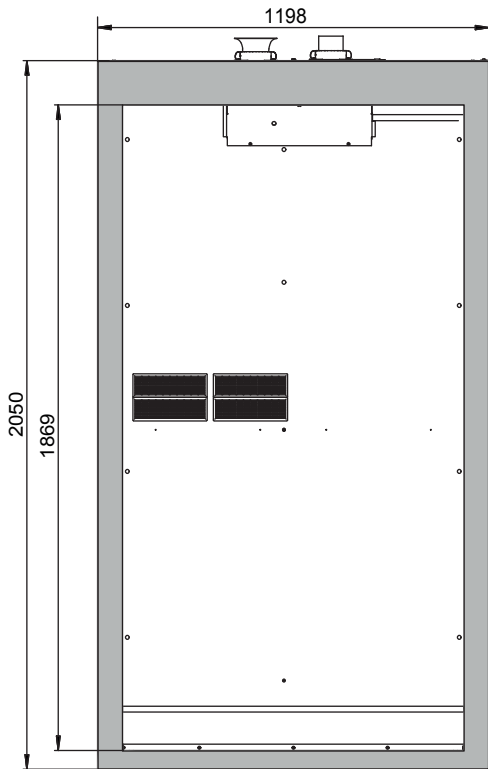

Side view

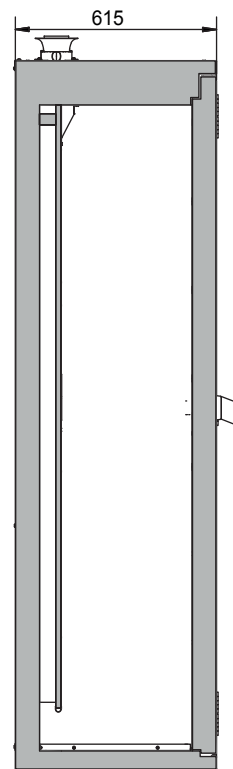

Top view

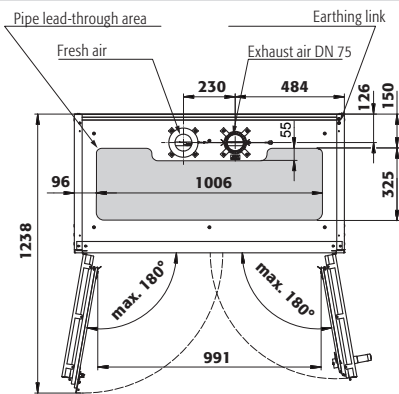

For further information please visit [www.asecos.com](http://www.asecos.com)