



Function / construction:

- Required occupational exposure limits are maintained
- Testing of the air equipment according to EN 14175 Part 3 (5.4.4)
- Maximum user safety
- Robust construction made of chemically resistant, anodised aluminium profiles
- Transparent side panes made from 5 mm (toughened safety glass)
- Highly effective capturing of hazardous materials inside the work station through special fresh air curtain technology
- Prepared for connection to the on-site exhaust air system and for electrical supply (230 V / 50 Hz)
- For mounting on existing working surfaces

Standard equipment

- Melamine resin coated rear wall
- Exhaust and fresh air monitoring with visual and audible alarm
- Interior lighting (energy-saving lamp, anti-glare arrangement)
- Transparent side walls
- Opaque, fold-away deflector

Accessories

- Transparent, fold-away deflector
- Working surfaces either melamine resin coated, made from stainless steel or ceramic
- Media ducts
- Support frames
- Media supplies (gas, water, air)

Technical data

External dimensions (mm)		Work height (mm)	
Height (external)	1400	Work height sitting	720
Height with support frame for sitting work	2085	Work height standing	900
Height with support frame for standing work	2265		
Width (external)	900	Weight (kg)	
Depth (external)	750	Weight	103 kg
Internal dimensions (mm)		Further information	
Clear height	1105	Point load per support	287 N
Width (internal)	865	Amount of air ducts	1 piece
Depth (internal)	650	Nominal volume flow	500 m ³ /h
Usable work surface (mm)		Differential pressure per air duct	96 Pa
Width usable work surface	790	Noise level (approx.)	32.0 dB
Depth usable work surface with media duct	530	Frequency	50/60 Hz
Depth usable work surface	640	Power consump. in operation	50 W
Max. charge of the working surface	3000 N/m ²	Max. current consumption	0.5 A
		Nominal voltage	230 V

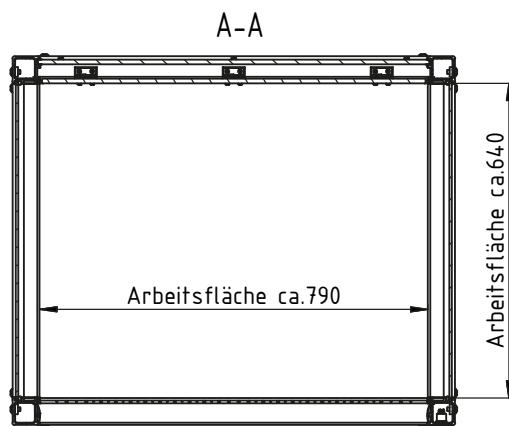
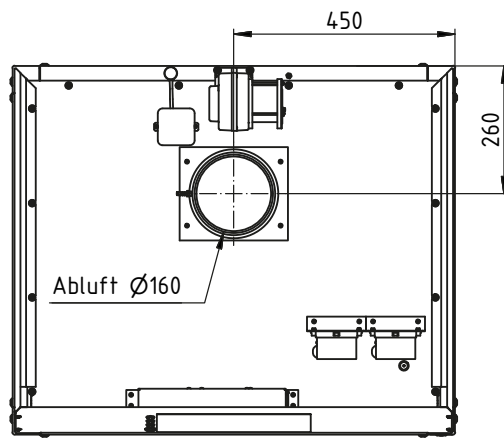
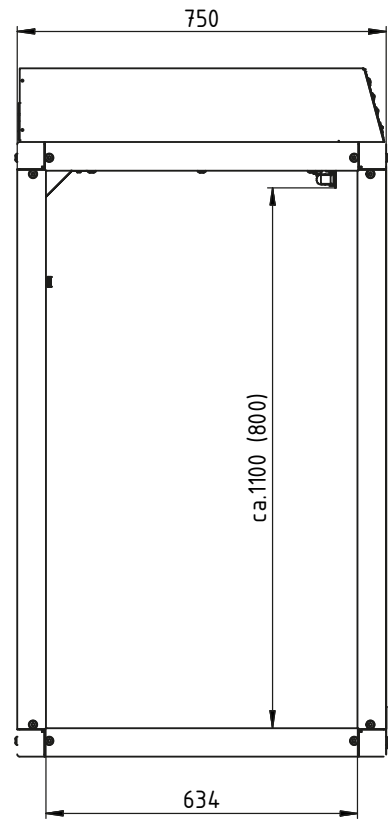
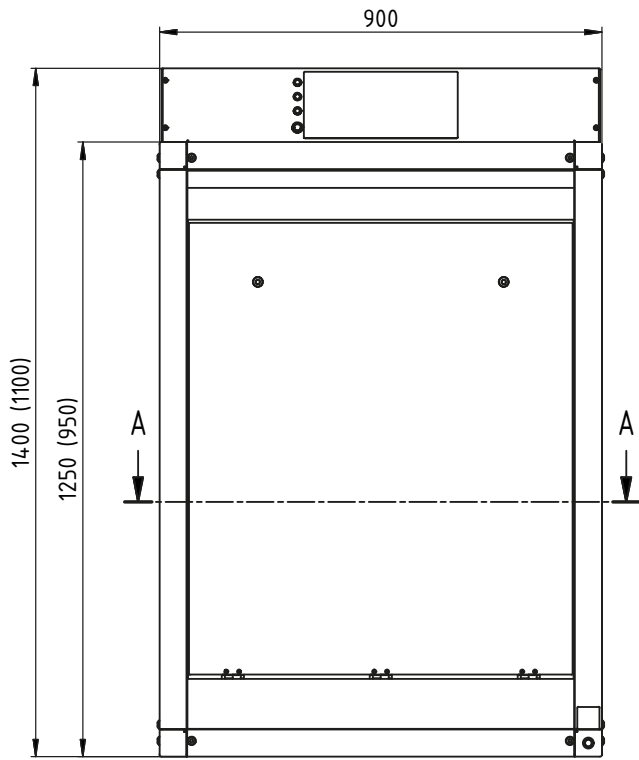

				Allgemein- toleranzen DIN 2768-m		Maßstab:	Gewicht:
						Halbzeug:	Material:
8				Datum	Name	GAP.125.090 (GAP.095.090)	
7			Bearb.	06.05.14	S.Bassermann		
6			Gepr.				
5			Norm				
4							
3						Ansichtzeichnung	
2							
1						Blatt	
Zust.	Änderung	Datum	Name			Bl.	
						© 2014 D. Faber	

For further information please visit www.asecos.com