

Function / construction:

- Required occupational exposure limits are maintained
- Testing of the air equipment according to EN 14175 Part 3 (5.4.4)
- Maximum user safety
- Robust construction made of chemically resistant, anodised aluminium profiles
- Transparent side panes made from 5 mm (toughened safety glass)
- Highly effective capturing of hazardous materials inside the work station through special fresh air curtain technology
- Prepared for connection to the on-site exhaust air system and for electrical supply (230 V / 50 Hz)
- For mounting on existing working surfaces

Standard equipment

- Melamine resin coated rear wall
- Exhaust and fresh air monitoring with visual and audible alarm
- Interior lighting (energy-saving lamp, anti-glare arrangement)
- Transparent side walls
- Opaque, fold-away deflector

Accessories

- Transparent, fold-away deflector
- Working surfaces either melamine resin coated, made from stainless steel or ceramic
- Media ducts
- Support frames
- Media supplies (gas, water, air)

Technical data

External dimensions (mm)		Work height (mm)	
Height (external)	1100	Work height sitting	720
Height with support frame for sitting work	1785	Work height standing	900
Height with support frame for standing work	1965		
Width (external)	1800	Weight (kg)	
Depth (external)	600	Weight	127 kg
Internal dimensions (mm)		Further information	
Clear height	855	Point load per support	336 N
Width (internal)	1765	Amount of air ducts	2 piece
Depth (internal)	500	Nominal volume flow	790 m ³ /h
Usable work surface (mm)		Differential pressure per air duct	71 Pa
Width usable work surface	1690	Noise level (approx.)	36.0 dB
Depth usable work surface with media duct	380	Frequency	50/60 Hz
Depth usable work surface	490	Power consump. in operation	70 W
Max. charge of the working surface	3000 N/m ²	Max. current consumption	0.5 A
		Nominal voltage	230 V

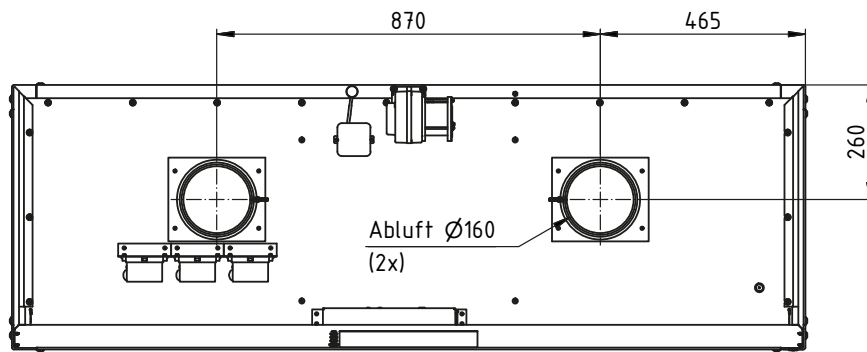
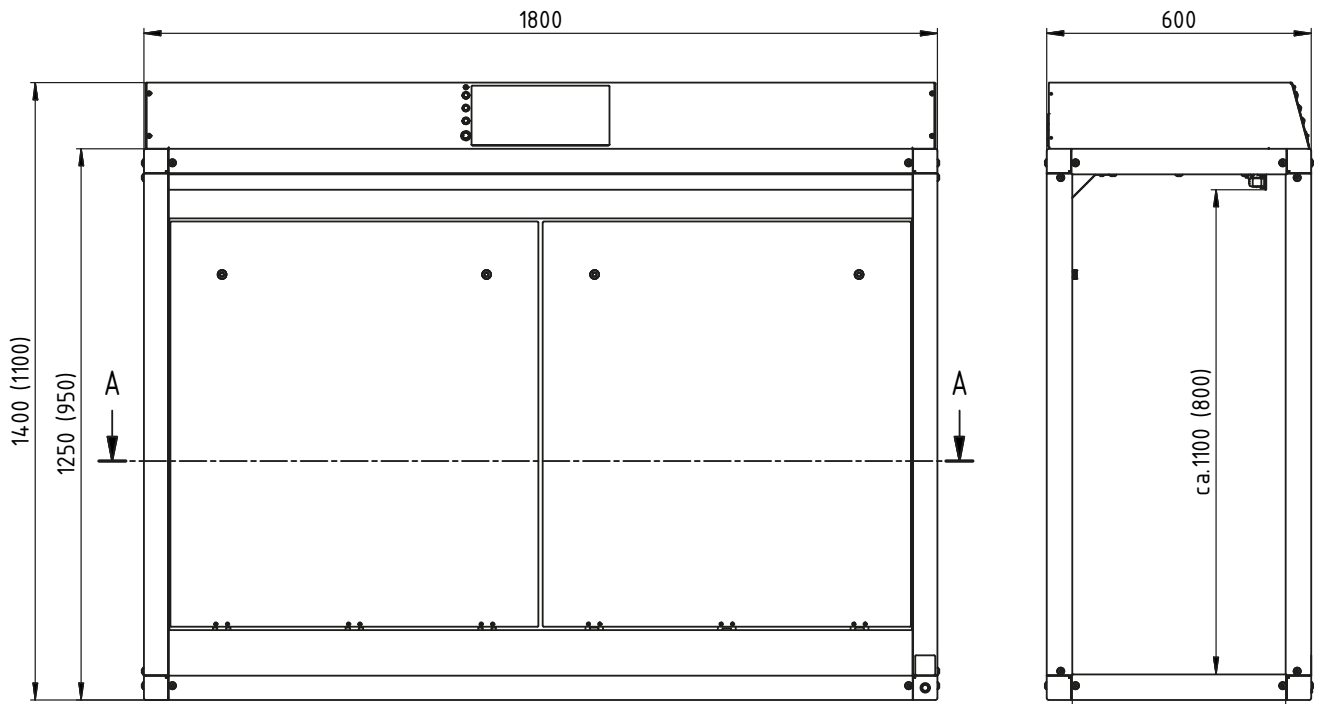

A-A

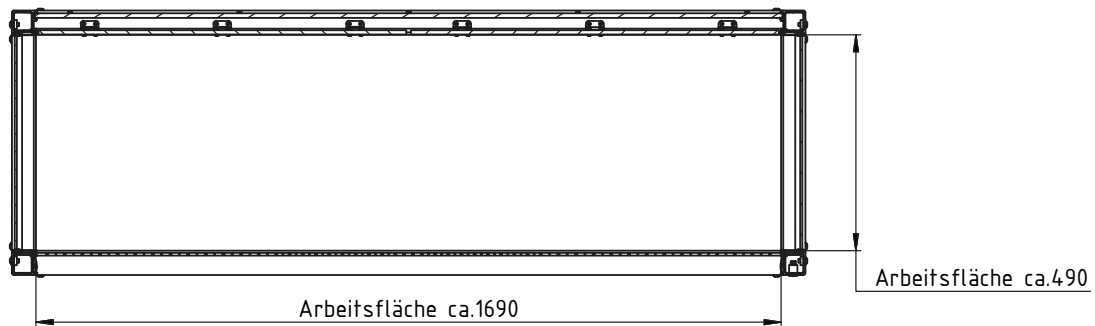

				Allgemein- toleranzen DIN 2768-m		Maßstab:	Gewicht:
						Halbzeug:	Material:
8				Datum	Name	GAP.125.180.060 (GAP.095.180.060)	
7				Bearb. 07.05.14	S.Bassermann		
6				Gepr.			
5				Norm			
4							
3				asecos		Ansichtszeichnung	Blatt
2							Bl.
1							© 2014 D.Tschöke
Zust.	Änderung	Datum	Name				

For further information please visit www.asecos.com